

# DMP-100

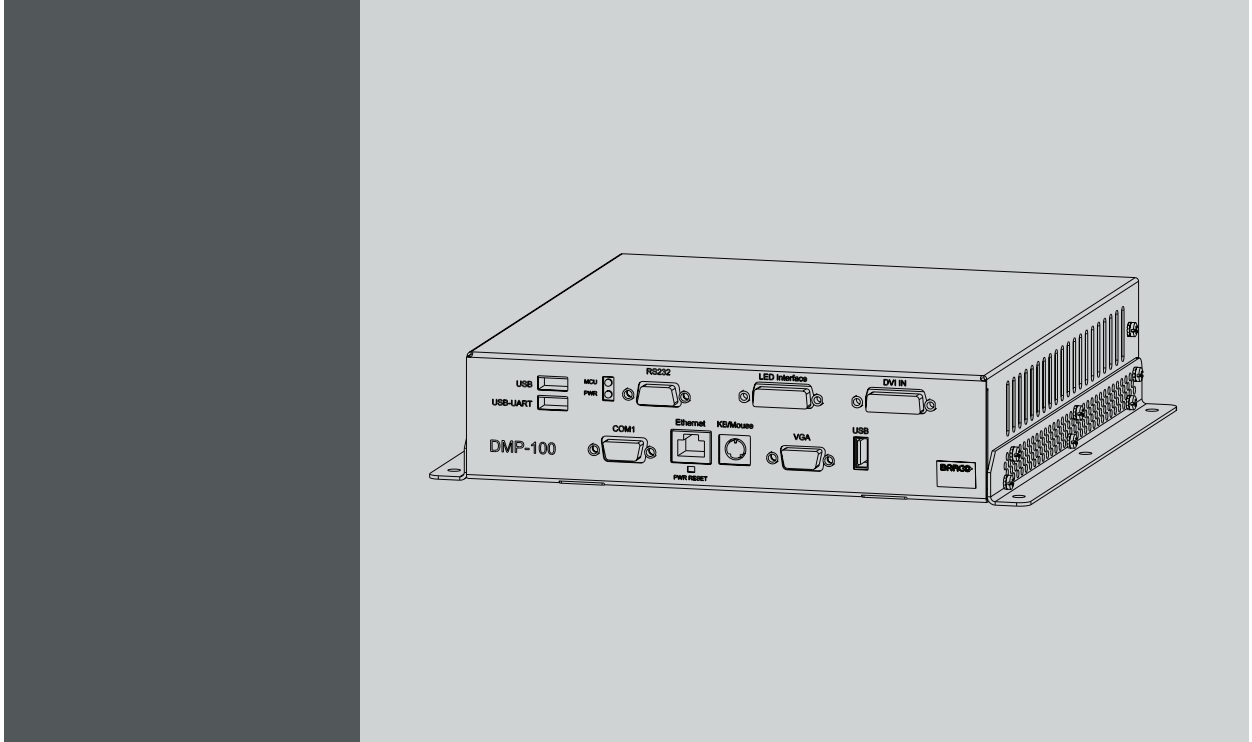

## Installation Guidelines

**Barco nv Media & Entertainment Division**  
Noordlaan 5, B-8520 Kuurne  
Phone: +32 56.36.82.11  
Fax: +32 56.36.883.86  
Support: [www.barco.com/esupport](http://www.barco.com/esupport)  
Visit us at the web: [www.barco.com](http://www.barco.com)

Printed in China

## Changes

Barco provides this manual 'as is' without warranty of any kind, either expressed or implied, including but not limited to the implied warranties or merchantability and fitness for a particular purpose. Barco may make improvements and/or changes to the product(s) and/or the program(s) described in this publication at any time without notice.

This publication could contain technical inaccuracies or typographical errors. Changes are periodically made to the information in this publication; these changes are incorporated in new editions of this publication.

The latest edition of Barco manuals can be downloaded from the Barco web site [www.barco.com](http://www.barco.com) or from the secured Barco web site <https://my.barco.com>.

## Guarantee and Compensation

Barco provides a guarantee relating to perfect manufacturing as part of the legally stipulated terms of guarantee. On receipt, the purchaser must immediately inspect all delivered goods for damage incurred during transport, as well as for material and manufacturing faults Barco must be informed immediately in writing of any complaints.

The period of guarantee begins on the date of transfer of risks, in the case of special systems and software on the date of commissioning, at latest 30 days after the transfer of risks. In the event of justified notice of complaint, Barco can repair the fault or provide a replacement at its own discretion within an appropriate period. If this measure proves to be impossible or unsuccessful, the purchaser can demand a reduction in the purchase price or cancellation of the contract. All other claims, in particular those relating to compensation for direct or indirect damage, and also damage attributed to the operation of software as well as to other services provided by Barco, being a component of the system or independent service, will be deemed invalid provided the damage is not proven to be attributed to the absence of properties guaranteed in writing or due to the intent or gross negligence or part of Barco.

If the purchaser or a third party carries out modifications or repairs on goods delivered by Barco, or if the goods are handled incorrectly, in particular if the systems are commissioned operated incorrectly or if, after the transfer of risks, the goods are subject to influences not agreed upon in the contract, all guarantee claims of the purchaser will be rendered invalid. Not included in the guarantee coverage are system failures which are attributed to programs or special electronic circuitry provided by the purchaser, e.g. interfaces. Normal wear as well as normal maintenance are not subject to the guarantee provided by Barco either.

The environmental conditions as well as the servicing and maintenance regulations specified in the this manual must be complied with by the customer.

## Copyright ©

All rights reserved. No part of this document may be copied, reproduced or translated. It shall not otherwise be recorded, transmitted or stored in a retrieval system without the prior written consent of Barco.

## Trademarks

Brand and product names mentioned in this manual may be trademarks, registered trademarks or copyrights of their respective holders. All brand and product names mentioned in this manual serve as comments or examples and are not to be understood as advertising for the products or their manufacturers.

## Federal Communications Commission (FCC Statement)

This equipment has been tested and found to comply with the limits for a class A digital device, pursuant to Part 15 of the FCC rules. These limits are designed to provide reasonable protection against harmful interference when the equipment is operated in a commercial environment. This equipment generates, uses, and can radiate radio frequency energy and, if not installed and used in accordance with the instruction manual, may cause harmful interference to radio communications. Operation of this equipment in a residential area may cause harmful interference, in which case the user will be responsible for correcting any interference at his own expense

## EN55022/CISPR22 Class A ITE (Information Technology Equipment)

Class A ITE is a category of all other ITE which satisfies the class A ITE limits but not the class B ITE limits. Such equipment should not be restricted in its sale but the following warning shall be included in the instructions for use:

**Warning :** This is a class A product. In a domestic environment this product may cause radio interference in which case the user may be required to take adequate measures.



---

# TABLE OF CONTENTS

<b>1. Safety</b> .....	<b>3</b>
1.1 Important Safety Instructions.....	3
1.2 Important Warnings.....	3
<b>2. Introduction</b> .....	<b>5</b>
2.1 General functionality.....	5
2.2 Order info DMP-100 processor .....	6
2.3 Content of a DMP-100 package .....	6
2.4 Technical summary .....	7
2.5 Dimensions of the DMP-100 processor.....	8
2.6 Components of the DMP-100 processor.....	8
<b>3. Physical installation of the DMP-100 processor</b> .....	<b>11</b>
3.1 Installation requirements .....	11
3.2 Connections of the DMP-100 processor.....	12
<b>4. Cables for the DMP-100 processor</b> .....	<b>15</b>
4.1 Cables .....	15
<b>5. Embedded PC</b> .....	<b>17</b>
5.1 Configuration .....	17
5.2 Embedded PC operating system, settings.....	18
5.3 Specifications of the embedded PC .....	20
<b>6. Configuration scheme</b> .....	<b>23</b>
6.1 Overview.....	23
<b>7. Control software</b> .....	<b>27</b>
7.1 RMS.....	27
7.2 Flashloader .....	27
7.3 Downloading Flash loader.....	27
7.4 Using Flash loader.....	27
<b>8. Maintenance</b> .....	<b>29</b>
8.1 Cleaning the cabinet.....	29
<b>9. Environmental information</b> .....	<b>31</b>
9.1 Disposal information.....	31



# 1. SAFETY

## 1.1 Important Safety Instructions

### Instructions:

- Read these instructions.
- Keep these instructions.
- Heed all warnings.
- Follow all instructions.
- Do NOT submerge fully or partly in water or other liquids.
- Clean only with materials or chemicals that are inert, nonabrasive, noncorrosive and non-marking. Consult the manufacturer for further advice should any doubts exist regarding any cleaning procedure.
- Do not block ventilation openings. Install in accordance with the manufacturers instructions.
- Do not install near any heat sources such as radiators, heat registers, stoves, or other apparatus (including amplifiers) that produce heat.
- Do not defeat the safety purpose of the polarized or grounding type plugs/sockets. If the provided sockets / plugs are damaged then replacement of the defective parts must be undertaken immediately.
- Protect the power/data cords from being walked on or pinched particularly at plugs, convenience receptacles, and the point where they exit from the apparatus. Replace damaged power/data cords immediately.
- Only use attachments/accessories specified by the manufacturer.
- Disconnect the power to this apparatus during lightning storms or provide suitable additional lightning protection. Unplug this apparatus when unused for long period of time.
- Refer all servicing to qualified service technicians/personnel. Servicing is required when the apparatus has been damaged in any way, such as power-supply cord or plug is damaged, the apparatus does not operate normally, or has been dropped.
- Use only with systems or peripherals specified by the manufacturer, or sold with the apparatus. Use caution during lifting/moving or transporting to avoid damage by possible tipping.

## 1.2 Important Warnings

### Important Warnings:

- **Risk of electric shock:**

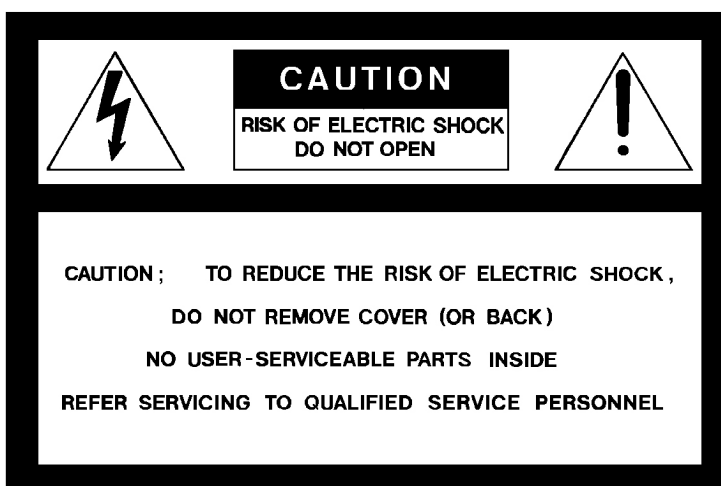

Image 1-1

Risk of electric shock. Do not open. To reduce the risk of electric shock, do not remove cover (or back). No user-serviceable parts inside. Refer servicing to qualified service personnel.

The lightning flash with an arrowhead within a triangle is intended to tell the user that parts inside this product may cause a risk of electrical shock to persons.

The exclamation point within a triangle is intended to tell the user that important operating and/or servicing instructions are included in the technical documentation for this equipment.

- **Maximum ambient temperature:**  
The maximum recommended ambient temperature for this equipment is 50°C.
- **Flammable materials:**  
Keep flammable materials away from the installation (such as curtains). A lot of energy is transferred into heat. The installation should be such that the amount of air flow required for safe operation of the equipment is not compromised. Proper ventilation must be provided.
- **This equipment MUST be earthed:**  
In order to protect against risk of electric shock, the installation should be properly grounded. Defeating the purpose of the grounding type plug will expose you to the risk of electric shock. This apparatus must be grounded (earthed) via the supplied 3 conductor AC power cord. (If the supplied power cord is not the correct variant, consult your dealer.)
- **Power system:**  
It is recommended to use a TN-S power distribution system (a power distribution system with a separate neutral and grounding conductor) in order to avoid large ground currents loops due to voltage differences in the neutral conductor. The total electrical installation should be protected by an appropriate rated disconnect switch, circuit breakers and Ground Fault Current Interrupters. The installation shall be done according to the local electrical installation codes. In Europe special attention should be given to EN 60364, the standard for electrical installation of buildings. In Germany VDE 0100 should be adhered to.
- **Mains cords:**  
The power cords delivered with this system have special properties for safety. They are not user serviceable. If the power cords are damaged, replace only with new ones. Never try to repair a power cord.
- **Use of an extension cord:**  
If an extension cord is used with this product, make sure that the total of the ampere ratings on the products plugged into the extension cord does not exceed the extension cord ampere rating. Also make sure that the total of all products plugged into the wall outlet does not exceed 15 amperes.
- **Cabinet openings:**  
Never push objects of any kind into this product through cabinet slots as they may touch dangerous high voltage points or short out parts that could result in a risk of fire or electrical shock.  
Never spill liquid of any kind on the product. Should any liquid or solid object fall into the cabinet, unplug the set and have it checked by qualified service personnel before resuming operations.



## 2. INTRODUCTION

### Overview

- General functionality
- Order info DMP-100 processor
- Content of a DMP-100 package
- Technical summary
- Dimensions of the DMP-100 processor
- Components of the DMP-100 processor

### 2.1 General functionality

#### Overview

The DMP-100 is a video processing device, designed to drive exclusively Barco LED walls. The DMP-100 is a powerful DVI signal processor that accepts a wide range of DVI input modes and processes them to drive Barco LED walls. The DMP-100 supports DVI output as the output format.

By using RMS-1 control software, the DMP-100 allows you to control and monitor a display using the digital output. RMS-1 will give you full control over everything from basic setup to configuration, advanced feature control and (automated) remote diagnostics.

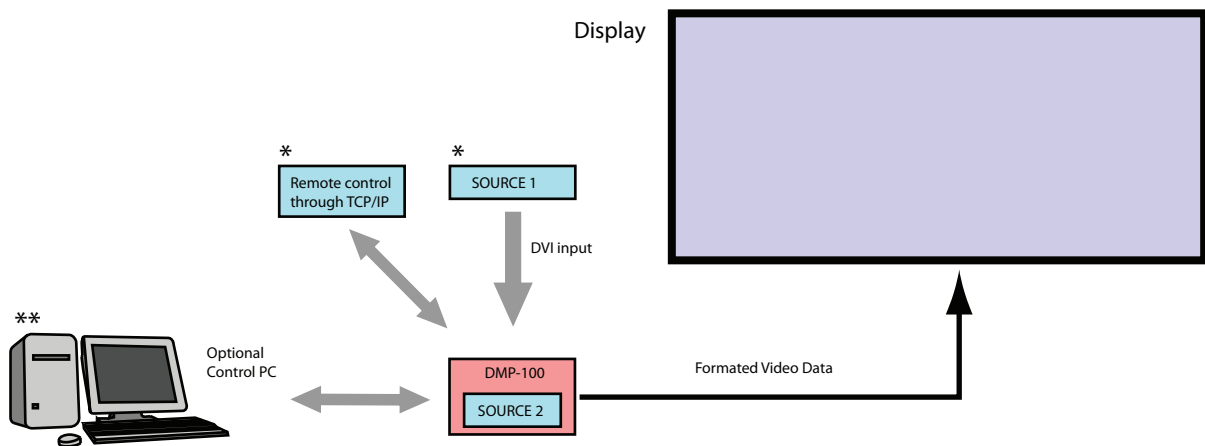

Image 2-1

\* Default connection.

\*\* Optional connection for maintenance reasons.



**SOURCE 2 is used as a back-up source in case one of the default connections does not exist.**

### Configuration of the DMP-100 processor

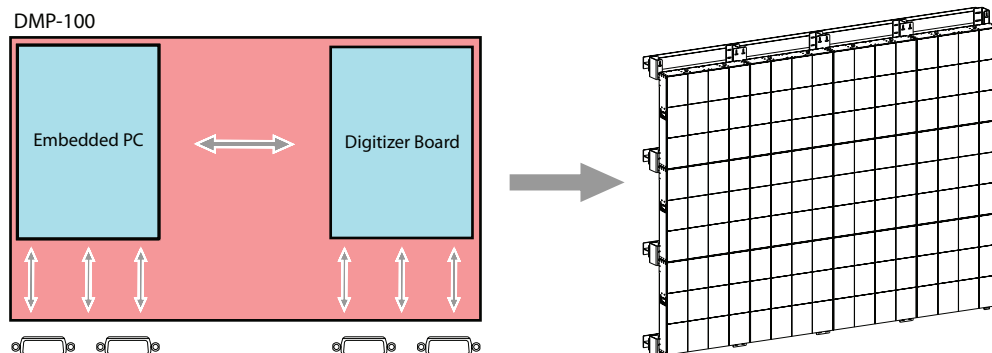

Image 2-2

The DMP-100 can be split up into two main parts: one part being the embedded PC, the other part being the processor itself which acts as a scaler for the provided input. Each part has its own interface connections and both parts are internally linked together.

## 2.2 Order info DMP-100 processor

**Order info:**

Article number	Description
R9828833	DMP-100 processor

## 2.3 Content of a DMP-100 package

**Package**

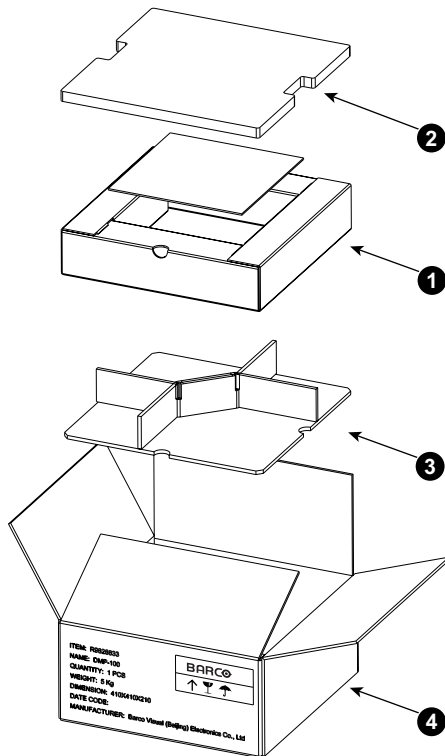

Image 2-3  
 1 Protective cover for the DMP-100 processor and installation manual.  
 2 Cover.  
 3 Container for all cables and accessories.  
 4 DMP-100 total package.

### What's inside of packaging

No.	Article number	Description	Quantity
1	R9828833	DMP-100	1
2	R59770263	Manual	1
3	R9851211	0.9 meter data cable with DVI connectors. Used to connect a display PC with the DMP-100 processor.	1
4	R9851210	5 meter data cable with DVI connectors. Used to connect the LED-WALL OUTPUT with a Barco DB-x20 billboard.	1
5	Z3499916	Data cable with SUBD connectors for RS232 connection between local control PC and COM1 RS232 input port of the DMP-100 processor.	1
6	R326103	Power cable with CEE7 plug. (used in Europe).	1
7	R3261115	Power cable with NEMA 5 — 15 plug. (used in USA).	1
8	Z3499213	Used to connect a LED-WALL and a Barco display. (T-16/TF-16/SP-20/S14/T20/TF-20/SLITE/S10XP)	1

About the cable's image please see the division "Cables", page 15

## 2.4 Technical summary

### Summary

Type	Value
Input	DVI input (supported resolutions 800x600 / 1024x768 / 1600x1200)
Compatibility	Barco DVI based LED walls, S10XP FX or newer (Barco NNI tiles are not supported)
Output	DVI-A, Barco LED protocol. (supported resolutions 800x600@60HZ / 1024x768@50HZ )
Scaler	Default set to cropping but scaling is possible.
Z-order control	Not available.
Window positioning	Intuitive positioning interface.
Connectors	RS 232 [RJ 11] — Ethernet [RJ 45].
Memory	1GB RAM. 4GB internal CF card.
Effects	Contrast, brightness and sharpness adjustment.
Ruggedness	IP10
Dimensions	Without screw pillar: 230 x 262.4 x 56 (W x D x H) With screw pillar: 247.4 x 262.4 x 56 (W x D x H)
Weight	±2.8 Kg (without package)
Operating temperatures	0 °C <> 50 °C
Power consumption	50 W.
Stacking	No stacking possible.
Chaining	No chaining possible.
Control software	RMS-1 (provided by Barco). Note: DMP-100 is not supported by Director Toolset

## 2.5 Dimensions of the DMP-100 processor

### Dimensions of the DMP-100 processor

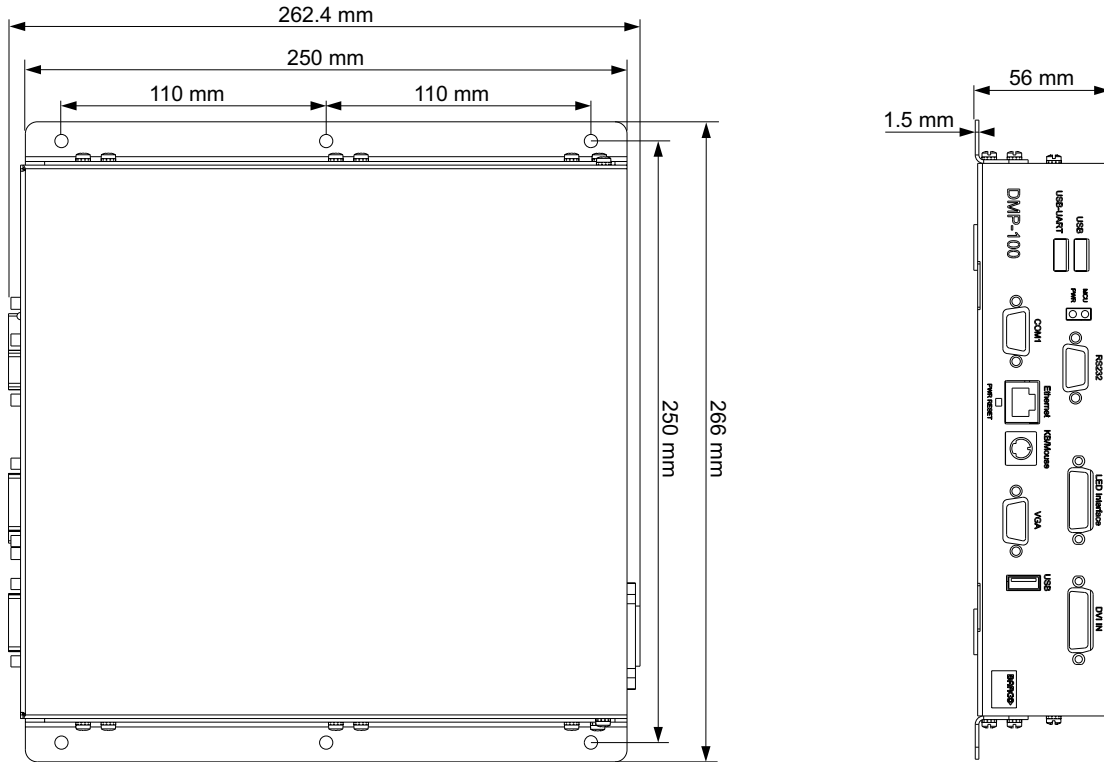

Image 2-4

## 2.6 Components of the DMP-100 processor

### Component overview

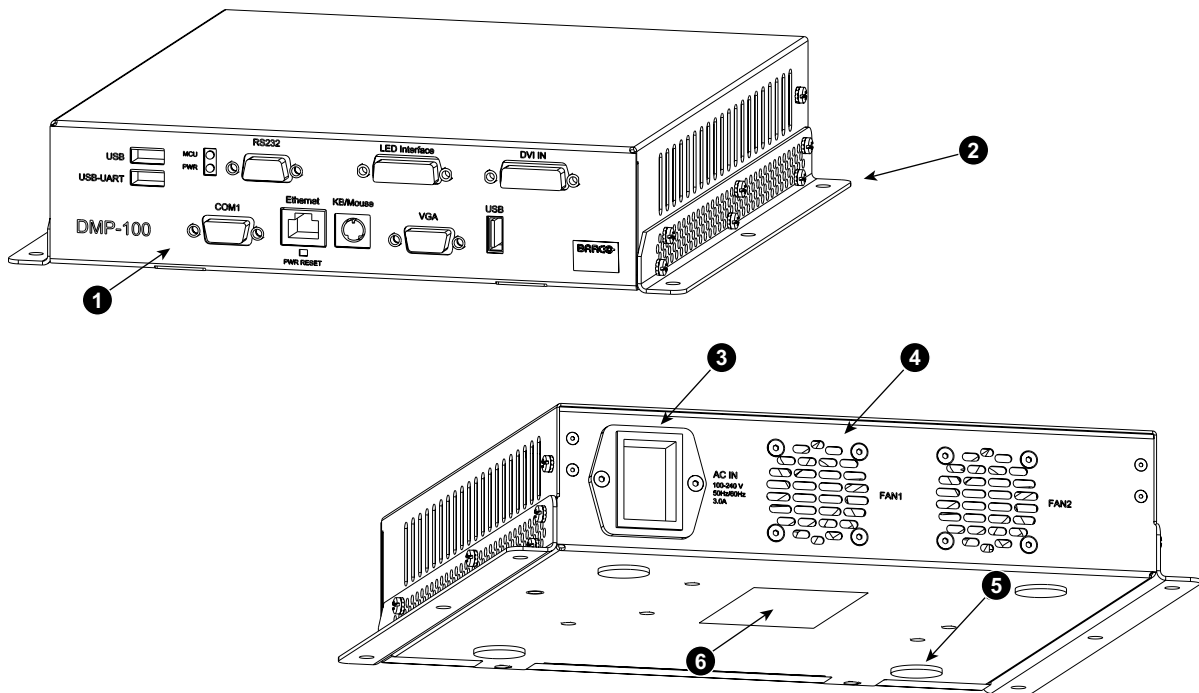

Image 2-5

- 1 Front side of the DMP-100 processor, including all connection interfaces, see "Connections of the DMP-100 processor", page 12
- 2 Positioning rail.
- 3 AC power connector with integrated switch.

- 4 Cooling fans.
- 5 Soft supports.
- 6 ETL certification label.



## 3. PHYSICAL INSTALLATION OF THE DMP-100 PROCESSOR

### Overview

- Installation requirements
- Connections of the DMP-100 processor

### 3.1 Installation requirements

#### Requirements

- The DMP-100 processor should not be placed in a built-in installation or enclosure unless proper ventilation is provided.
- When using the unit in a multi unit rack assembly or closed assembly, the ambient temperature inside the assembly may not exceed the rated ambient temperature (0 -50°C) of the processor. The installation should be such that the amount of air flow required for safe operation of the equipment is not compromised.
- When building in the DMP-100 processor into a rack with cover door, be aware that a space of minimum 85 mm is needed between the indicated reference and the cover door. This space is needed to guide the input cables to the inputs.

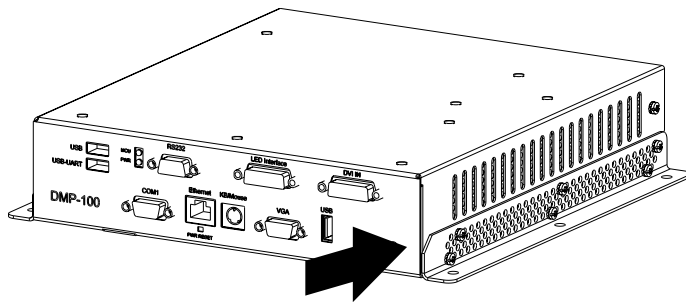

Image 3-1

The front side of the DMP-100 processor is considered as reference for this installation requirement.

- The DMP-100 processor will require that air flows freely in vent holes. Blocking these holes will greatly reduce the reliability of the unit and lead to the possibility of overheating.
- The DMP-100 processor should operate from an AC power source. The DMP-100 processor is equipped with an auto-ranging power supply from 100 to 240 volt (50–60 Hertz).
- When installed in a rack, the mounting should be such that no hazardous condition is achieved due to uneven mechanical loading.
- When the mains switch located on the back of the DMP-100 processor is not accessible due to rack mounting, the socket outlet supplying the rack shall be installed near the equipment and be easily accessible or a readily accessible disconnect device shall be incorporated in the fixed wiring. When using a rack in an installation it is advisable to log the serial number of the device and to activate the warranty figure by registering utilizing the included form.
- Do not place the DMP-100 processor on an unstable cart, stand or table. The device may fall, causing personal injury and serious damage to the processor.
- The data path between the DMP-100 processor and the LED display may not exceed ten (10) meter.

### 3.2 Connections of the DMP-100 processor

#### Front panel connections

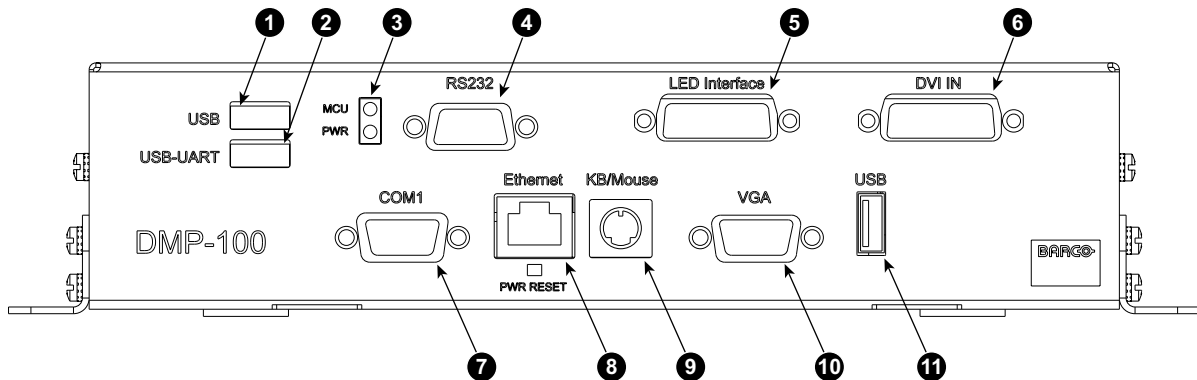

Image 3-2

Nr.	Connector	Description
1	USB interface	Common USB interface for the embedded PC.
2	USB — UART interface	USB interface for external control PC which can be used to update software or firmware.
3	Indicator light	PWR: indicates power supply. MCU: indicates the MCU work status.
4	RS-232	Used by RMS software on an external control PC to communicate with the DMP-100 processor.
5	LED interface	DVI Output to LED wall (Barco proprietary protocol).
6	DVI input	External DVI source signal input port.
7	COM 1	Embedded PC COM 1 port .
8	Ethernet interface	Embedded PC Ethernet interface for remote control.
9	Mouse interface	Embedded PC mouse / Keyboard port.
10	VGA interface	Embedded PC VGA display port.
11	USB interface	Embedded PC USB port.



**WARNING:** Connectors number 1, 2 and 11 are all USB interfaces but there is a significant difference between them.

Connector 1 and 11 are connected with the embedded PC board and are therefor embedded PC USB interfaces.

Connector 2 is connected with the embedded digitizer board and is used to update software and firmware.



**WARNING:** Connectors number 4 and 7 are both RS—232 interfaces but there is a significant difference between them.

Connector 7 is connected with the embedded PC board and is therefor an embedded PC COM 1 port.

Connector 4 is connected with the processor board and is used by the external control PC to communicate with the DMP-100 processor.





**WARNING:** The power connection is located on the back side of the DMP-100 processor and includes an integrated interruption switch.



Image 3-3  
14-9000094-90



## 4. CABLES FOR THE DMP-100 PROCESSOR

### 4.1 Cables

List with available cables

Article number	Description	Image
Z3499213	Used to connect a LED-WALL and a Barco display. (T-16/TF-16/SP-20/S14/T20/TF-20/SLITE/S10XP)	Image 4-1
R326103	Power cable with CEE7 plug. (used in Europe).	Image 4-2
R3261115	Power cable with NEMA 5 — 15 plug. (used in USA).	Image 4-3
R9851211	0.9 meter data cable with DVI connectors. Used to connect a display PC with the DMP-100 processor.	Image 4-4
R9851210	Five meter data cable with DVI connectors. Used to connect the LED-WALL OUTPUT with a Barco DB-x20 billboard.	Image 4-5
Z3499916	Data cable with SUBD connectors for RS232 connection between local control PC and COM1 RS232 input port of the DMP-100 processor.	Image 4-6



Image 4-1  
Z3499213



Image 4-2  
R326103



Image 4-3  
R3261115



Image 4-4  
R9851211



Image 4-5  
R9851210



Image 4-6  
Z3499916



## 5. EMBEDDED PC

### Overview

- Configuration
- Embedded PC operating system, settings
- Specifications of the embedded PC

### 5.1 Configuration

#### Configuration of the embedded PC

The embedded PC is a powerful built-in PC which is used as control PC. This offers the DMP-100 processor its benefit compared to other digitizers, the use of an external control PC is no longer needed. To operate the embedded PC, connections 1 and 3 can be used.

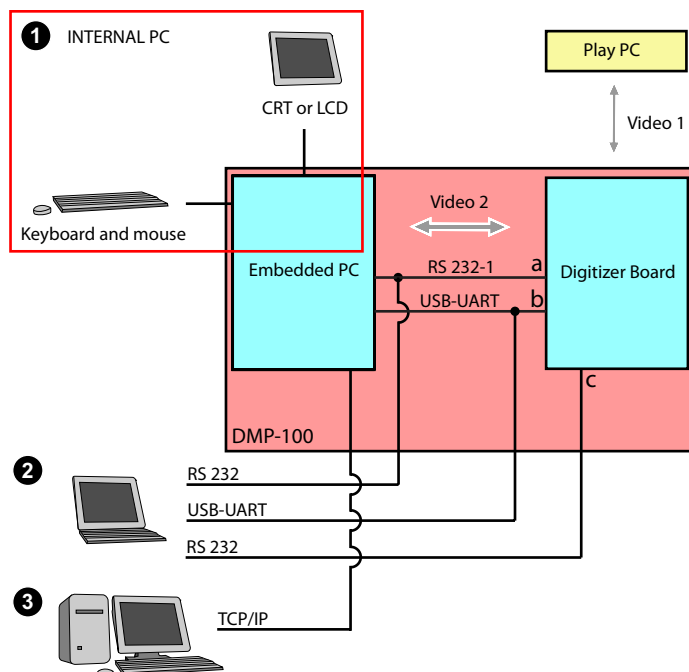

Image 5-1

- 1 Connection 1: Connecting a CRT/LCD display, keyboard and mouse.
  - 2 Connection 2: Connecting a laptop.
  - 3 Connection 3: Remote control.
- a Port used to run the LED toolset or RMS-1. (used when operating)  
 b USB — UART transmitter. (used during maintenance)  
 c RS 232 transceiver. (used during maintenance)

#### Connection 1: Manipulating the embedded PC directly

By plugging in a CRT or LCD display, a keyboard and a mouse the embedded PC can be manipulated directly.



**When changing to this configuration, make sure that the control software of the configurations described below is switched off. Consult the manual of the control software for more information.**

#### Connection 3: Off-site manipulation (remote control), used as default

By connecting through the TCP/IP (Ethernet) port, the embedded PC can be manipulated through remote control.



**WARNING:** The Play PC is always used as default. If the Play PC does not exist or has been damaged, the DMP-100 processor will automatically use the embedded PC as a back up solution. If the play PC has been damaged, a notification will be given by the used control software.

If the Play PC is not used, data can be provided to the embedded PC by using the 4GB CF card installed inside the DMP-100 processor. Content can be put on the CF card by connecting a USB device to the DMP-100 or by connecting by remote control (TCP/IP connection).

## 5.2 Embedded PC operating system, settings

### What should be done ?

During installation there are several settings which must be verified and set in the embedded PC operating system. Failure to set some of these can lead to loss of data or incorrect calculations of time based functions.

### Set the display resolution

1. Right click on the desktop to open the context menu.

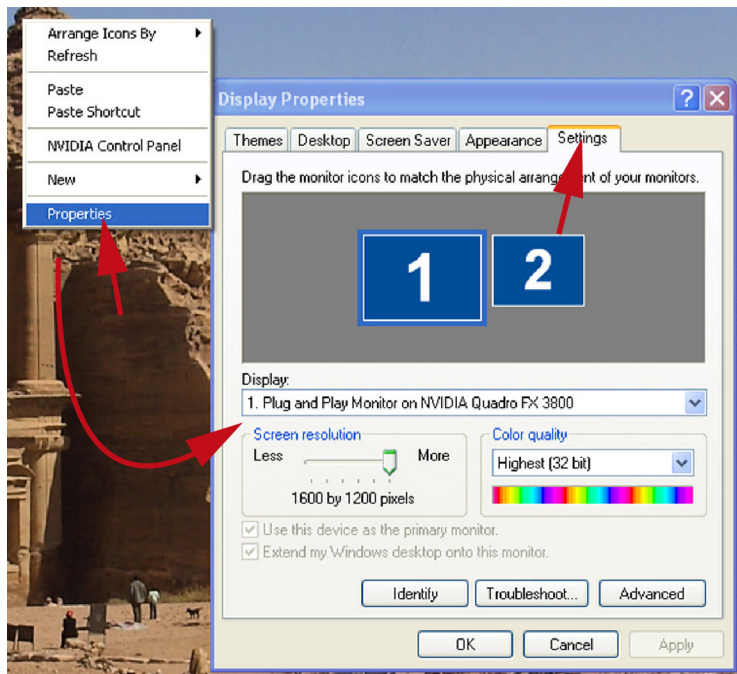

Image 5-2

2. Select *Properties*.

The *Properties* window opens.

3. Click on **Settings** tab.

4. Adjust the resolution of the primary display.

**Note:** By default, the secondary display is set to 1024x768 and should normally not be adjusted. There are restrictions of supported resolutions of the secondary adapter since it is used as a backup input for the DMP-100.

5. Click **OK**.

### Configure the time zone, date, and time

1. Double click the time in the system tray.

Or,  
click **Start** → *Control panel*. From the *Classic View* of that panel, double click on *Date and Time*.

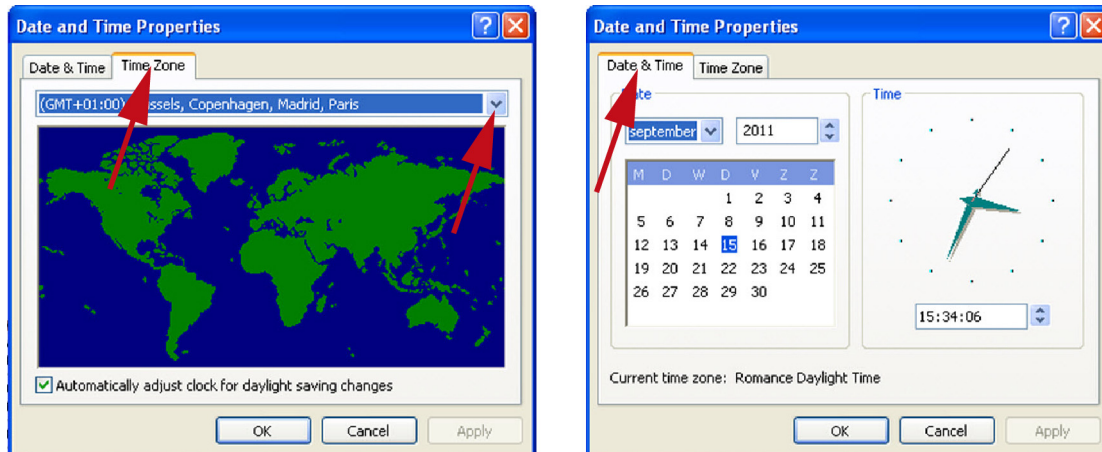

Image 5-3

2. Click on **Time Zone** tab.
3. Click on the drop down list to select the time zone that corresponds to the time zone where the DMP-100 is being installed.
4. Click on **Date & Time** tab.
5. In the *Date* section choose the correct day, month, and year.
6. In the *Time* section set the time corresponding to the correct time of the time zone using the up down buttons next to the current time.
7. Click **OK**.

#### Disable the write cache of the disk

1. Open **My Computer** from the desktop  
Or,  
click on **Start** → *My computer*.
2. Right click on the C drive and select *Properties* (1).

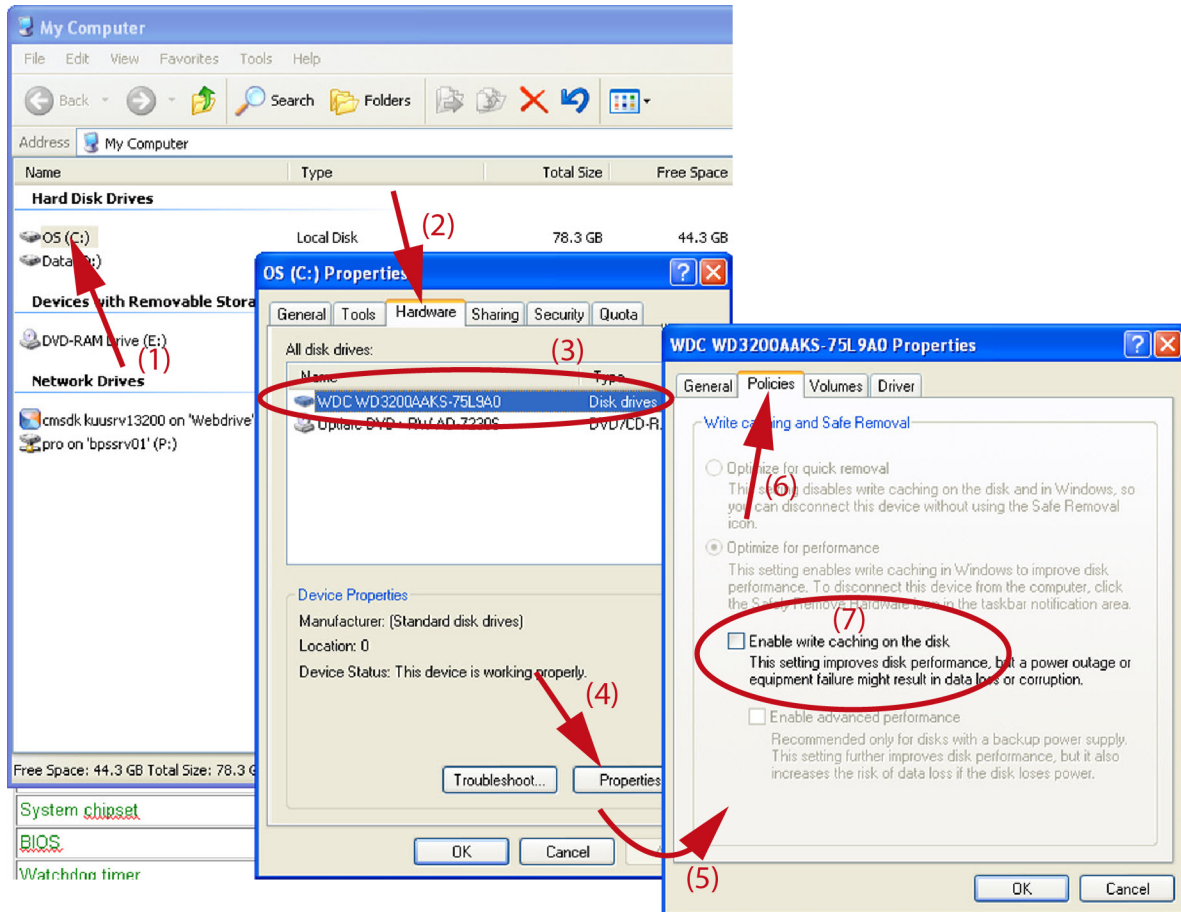

Image 5-4

3. Click on the **Hardware** tab (2).
4. Make sure the disk drive corresponding to the C: drive is selected in the *All disk drives* section (3).
5. Click **Properties** (4).
6. Click on the **Policies** tab (6).
7. Uncheck the *Enable write caching on the disk* box (7).
8. Click **OK**, then click **OK** once more to close the drive properties dialog.
9. If prompted, reboot the PC

### 5.3 Specifications of the embedded PC

#### Standard 3.5" biscuit SBC functions

Type	Value
CPU	Embedded Intel Atom N270 1.6 GHz Processor
System memory	DDR2 Memory support up to 2GB
2nd cache memory	512 KB.
System chipset	Intel 945GSE
BIOS	AWARD 4Mbit
Watchdog timer	Programmable 1~255sec
Expansion interface	PCI-104.
Memory	1GB RAM / 4GB internal CF card
Battery	Lithium 3V/210mAH
Power management	APM1.2, ACPI3.0, wake on LAN, and modem ring-in functions



Enhanced IDE interface	ICH7M support Single, independent IDE signal channel Supports one CF device
Serial ports	Two serial RS-232 ports, COM1(RS-232), DB-9 COM2(RS-232/422/485)
Parallel port	26-pin flat-cable connector
Keyboard / mouse connector	PS/2 Keyboard and Mouse interface Connector: Mini-Din 6P at coastline
Audio	High Definition Audio(HD)
USB	USB 2.0 compliant Ports
Solid state disk (SSD)	Supports Compact Flash Card Type I/II
GPIO	8-bit general purpose input/output
SMBus	System Management Bus for advanced monitoring / control interface.

### VGA / LVDS interface

Type	Value
Chipset	Intel 945GSE
Memory Size	Up to 64MB of dynamic video memory allocation
Resolution	CRT display Mode: Supports QXGA up to 2048x1536 TTL display Mode: Up to 800x600
TTL LCD	Supports 18-bit TTL LCD
LVDS LCD	Supports 36-bit LVDS LCD
Dual independent display	CRT+LVDS (36-bits) CRT+TTL (18-bits)

### Ethernet interface

Type	Value
Chipset supports	Realtek 8110SC
Speed	1000 Mbps
Interface	1xRJ45 connector.
Standard	Compliant with IEEE 802.3, IEEE 802.3u, IEEE 802.3x, IEEE 802.ab

### Mechanical and environmental specifications

Type	Value
Dimensions	145 x 102 mm (5.9" x 4.2").
Power supply type	AT/ATX
Power requirements	ATX: +5V±5%, ±12V±5% AT: 5V only to boot up (12V is optional for LCD inverter and add on card)
Power consumption	Typical (WinXP Idle Mode): +5V@1.9A, +12V@0.07A Max (Test in HCT):+5V@2.38A, +12V@0.09A
Operating temperature	0 ~ 50°C (32 ~ 122°F).
Operating humidity	0% ~ 90% relative humidity, non-condensing.
Weight	0.85 kg.



## 6. CONFIGURATION SCHEME

### 6.1 Overview

#### Scheme

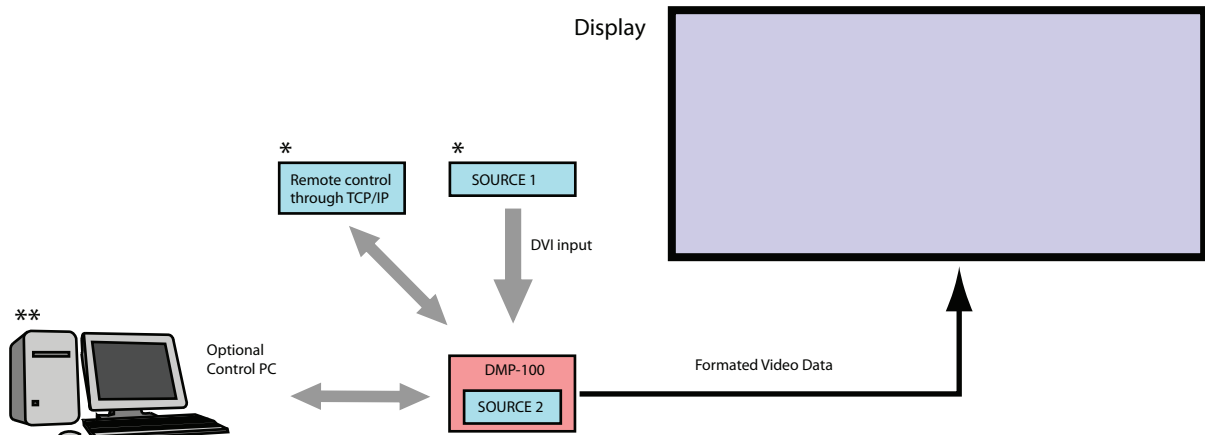

Image 6-1

\* The fiberlink is optional.

\*\* Default connection.

\*\*\* Optional connection for maintenance reasons.



A DMP-100 is sufficient to drive one Barco LED wall.

#### 3 different configurations;

1. Default through remote control (TCP/IP).
2. By connecting an external laptop, keyboard and mouse.
3. By plugging in a display, keyboard and mouse.

#### How to set up the remote control configuration?

1. Make sure the power of the DMP-100 is turned off.
2. Connect the internet cable to the Ethernet port and a data cable to connect the DMP-100 processor with the LED-wall through the LED interface port.

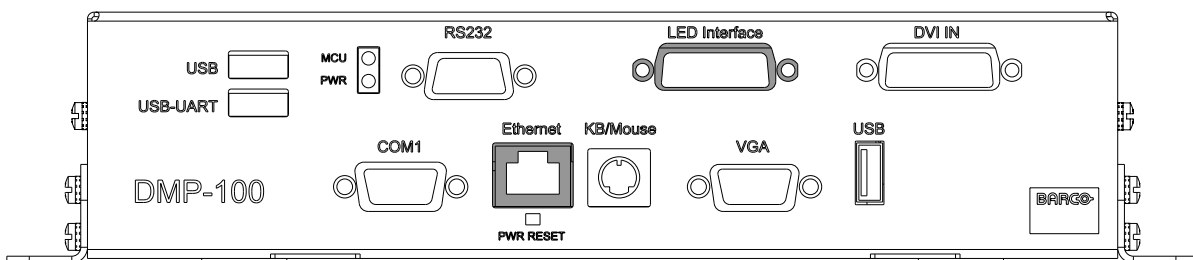

Image 6-2



Image 6-3

3. Turn on the power of the DMP-100.  
**Note:** The Led's indicated with "PWR" and "MCU" will light up.
4. Use the REAL VNC application on the remote PC to login to the embedded PC.
5. Use the RMS control software to communicate with the DMP-100 processor.



**WARNING:** The DMP-100 processor does not support the "HOT SWAP" function. The LED-wall and the DMP-100 should be switched off before any cable can be disconnected or reconnected.



Use the Flash Loader software to download updates on the software and firmware used by the DMP-100 processor.

### How to connect a laptop to locally control the DMP-100 processor?

1. Turn on the power of the DMP-100.  
**Note:** The Led's indicated with "PWR" and "MCU" will light up.
2. Wait until the operating system and the RMS software has loaded.
3. Shut down the operating software.
4. Wait until the operating system has fully shut down.
5. Connect the DVI cable ( R9851210) between the DMP-100 processor and the LED-wall, using the LED Interface port.

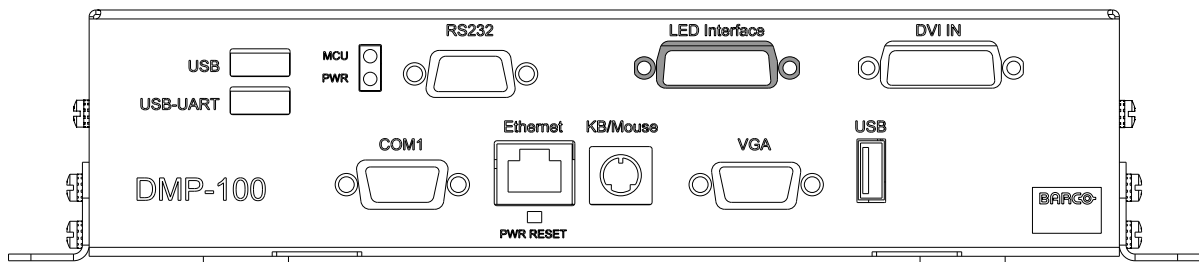

Image 6-4

6. Connect a serial line (Z3499916) from the control PC to the RS232 interface.

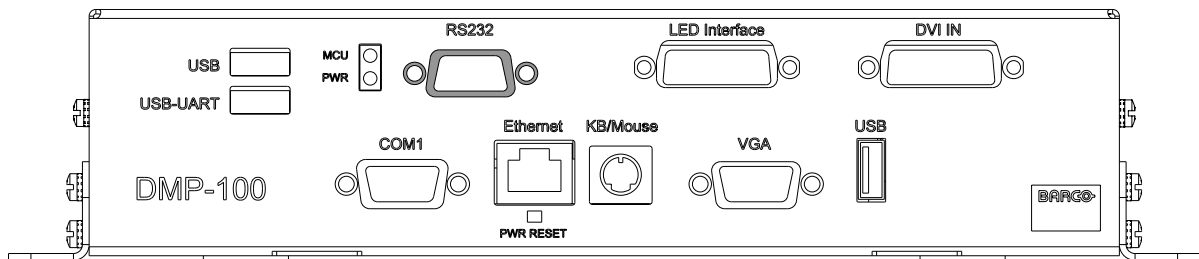

Image 6-5

7. Use the connected laptop to communicate with the DMP-100 processor.



If a display or billboard is up and running, the user can start from step 3.



Connect the control PC with the DMP-100 processor, using a USB line on the USB-UART port, to update the software and firmware used by the DMP-100 processor through the embedded Flash Loader software.

### How to manipulate the embedded PC by connecting a display, keyboard and mouse?

1. Turn off the power of the DMP-100.
2. Disconnect the RS232 cable if one is connected to the RS232 interface.
3. Connect the DVI cable ( R9851210) between the DMP-100 processor and the LED-wall, using the LED Interface port.

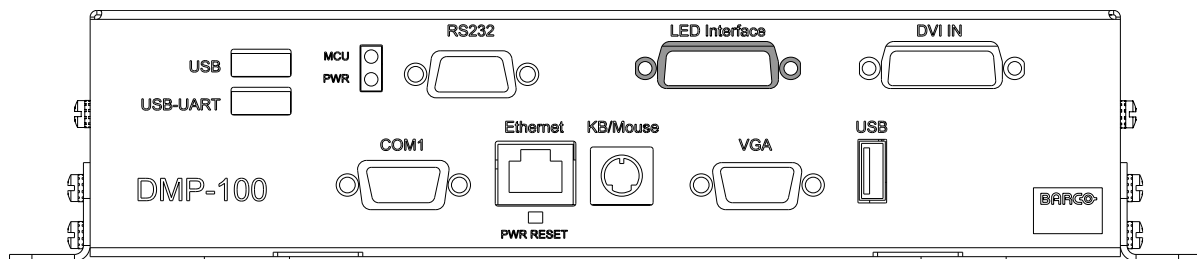

Image 6-6

4. Connect a CRT or LCD display to the DMP-100 processor through the VGA port.

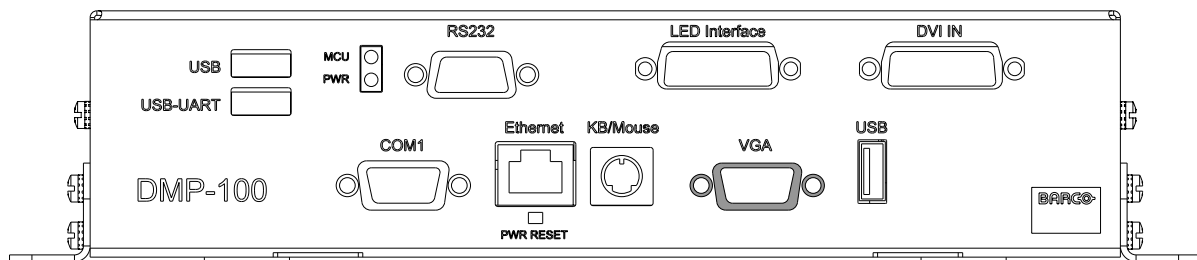

Image 6-7

5. Connect a keyboard and a mouse, using the KB/Mouse port or USB port.

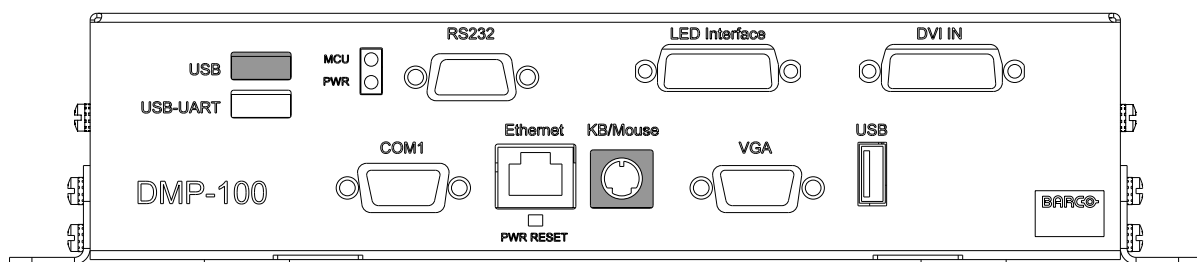

Image 6-8

6. Turn on the CRT or LCD display.
7. Turn on the power of the DMP-100 and restart the operating system.  
**Note:** The Led's indicated with "PWR" and "MCU" will light up.
8. Wait until the operating system and RMS software are up and running.
9. Operate the DMP-100 by using the connected peripherals.



**WARNING:** Before turning off the DMP-100 processor, please first shut down all windows operation systems and the embedded PC.

## 6. Configuration scheme

---



Alternatively, step 2 and 3 can be carried out together by pushing the reset button.

---



Use the Flash Loader software to download updates on the software and firmware used by the DMP-100 processor.

---

---

## 7. CONTROL SOFTWARE

### 7.1 RMS

---

#### General introduction

RMS control software is running on the embedded PC inside DMP-100 to configure and control the DMP-100 and associated LED wall from basic set-up to advanced features such as input timing, brightness control setup and monitoring tools.



Image 7-1



**CAUTION:** Refer to the manual of the RMS software (R59770142) for more information about installation and usage guidelines.

---

### 7.2 Flashloader

---

#### General introduction

Flash loader is a stand alone program to update the software / firmware of the DMP-100 processor. The flash loader software can run from an embedded PC or an external control PC. The embedded PC already has this software pre-installed.



Flash loader runs on a Windows platform.

---

### 7.3 Downloading Flash loader

---

#### How to download Flash loader?

These Flash loader software can be downloaded from the secured Barco web site <https://my.Barco.com>. Fill in the description in the search engine to find and download the correct files.

### 7.4 Using Flash loader

---

#### How to use Flash loader

1. Setup Flash loader.
2. Run Flash loader.

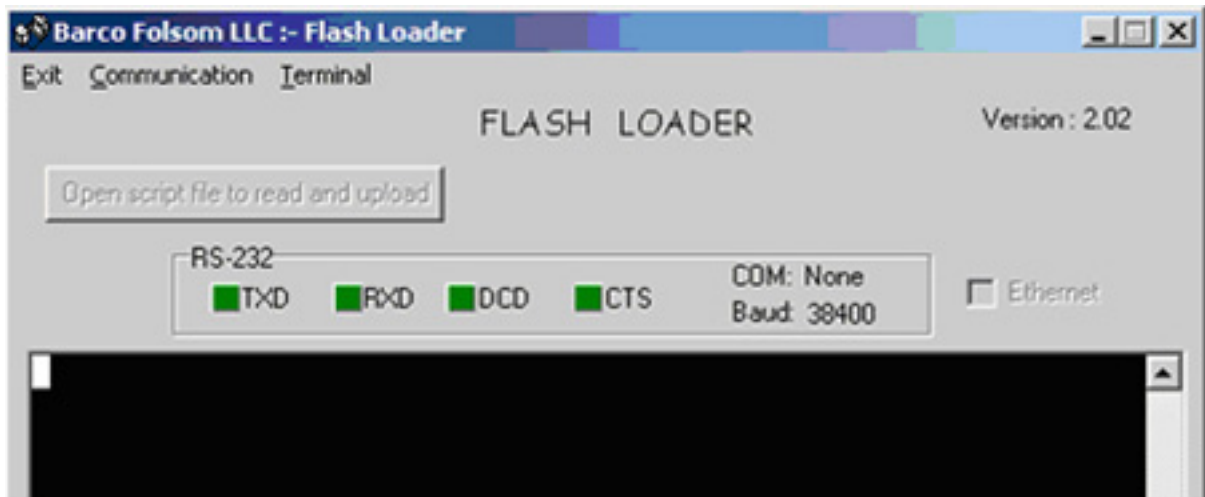

Image 7-2

3. Click **Communication > RS232 Config > Baud**, and select **38400**.
4. Click **Communication > RS232 Config > COM Port**, and select the COM port on the PC to which the DMP-100 is connected. If no other programs are using the port, the "Established communications" message appears at the bottom of the Flash Loader.  
**Note:** *If no other programs are using the port, the "Established communications" message appears at the bottom of the Flash Loader.*
5. To upload files to the DMP-100, click "**Open script file to read and upload**".
6. In the dialog, select "**Upload\_All.sld**" and click **Open**. The DMP-100 unit should immediately display the "**System in LOADER MODE**" message.
7. It takes several minutes to load the flash memory. When complete, the Flash Loader utility displays the "**Upload Complete**" message. Click **OK** to continue.
8. Cycle power on the DMP-100.
9. Exit the Flash Loader utility.



## 8. MAINTENANCE

### 8.1 Cleaning the cabinet

---



**CAUTION:** Do not use liquid cleaners or aerosol cleaners. Never use strong solvents, such as thinner or benzine, or abrasive cleaners, since these will damage the cabinet.

---

#### Necessary tools

Damp cloth.

#### How to clean the cabinet

1. Unplug the DMP-100 processor from the wall outlet before cleaning.
  2. Clean the cabinet with a damp cloth. Stubborn stains may be removed with a cloth lightly dampened with mild detergent solution.
- 



To keep the cabinet looking brand-new, periodically clean it with a soft dry cloth.

---



---

## 9. ENVIRONMENTAL INFORMATION

### 9.1 Disposal information

---

#### Disposal Information

This equipment has required the extraction and use of natural resources for its production. It may contain hazardous substances for health and environment. In order to avoid the dissemination of those substances in the environment and to diminish the pressure on natural resources, we encourage you to use the appropriate take-back systems. Those systems will reuse or recycle most of the materials of your end of life equipment in a sound way.



The crossed-out wheeled bin symbol invites you to use those systems. If you need more information on the collection, reuse and recycling systems, please contact your local or regional waste administrator. You can also contact us for more information on the environmental performances of our products.

#### Disposal of batteries in the product



The crossed-out wheeled bin symbol indicates that batteries and accumulators must be collected and disposed of separately from household waste.

If the battery or accumulator contains more than the specified values of lead (Pb), mercury (Hg) or cadmium (Cd) according to the Battery Directive 2006/66/EC, these chemical symbols will appear below the crossed-out wheeled bin symbol.

By participating in separate collection of batteries, you will help to ensure proper disposal and to prevent potential negative effects on the environment and human health.



## Revision Sheet

To:

- ▶ **Barco nv Media & Entertainment Division/Documentation**  
Noordlaan 5, B-8520 Kuurne  
Phone: +32 56.36.82.11, Fax: +32 56.36.88.24  
Support: [www.Barco.com/esupport](http://www.Barco.com/esupport), Web: [www.barco.com](http://www.barco.com)

From: \_\_\_\_\_

Date: \_\_\_\_\_

Please correct the following points in this documentation (**R59770263/06**):

page	wrong	correct